

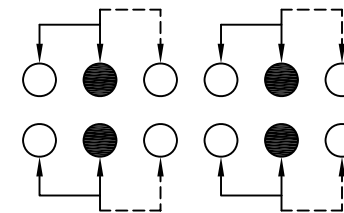

CAD FILE:

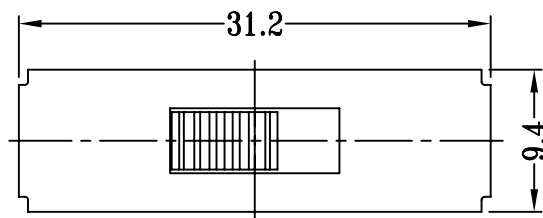

SCHEMATIC (SHORTING)

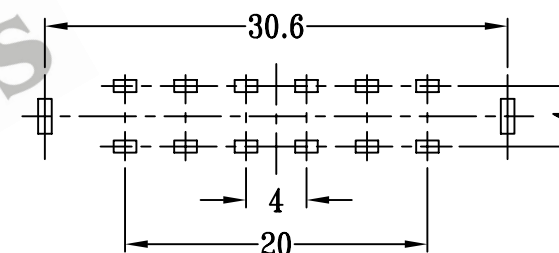
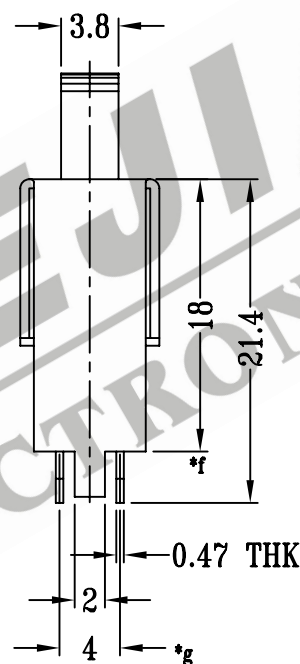
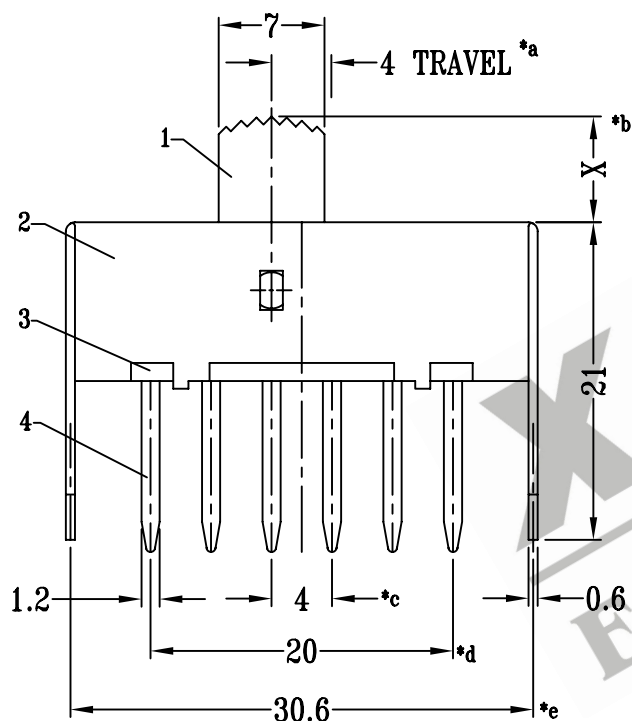

P.C.B LAYOUT

注:带"\*"表示关键尺寸(7个)

8					TOLERANCE UNLESS SPECIFIED	SHENZHEN XIEJIA ELECTRONICS CO.,LTD.				
7	STEEL BALL	STEEL	2	NATURAL						
6	SPRING	STEEL WIRE	1	TEMPER	WITHIN : 1.5±0.1mm	ISSUE	DATE	DESCRIPTIONS		APPD.
5	CONTACT CLIP	PBS STRIP	4	Ag PLATED	OVER : 1.5±0.2mm					
4	TERMINAL	BRASS STRIP	12	Ag PLATED OVER Ni PLATED	TITLE : VERTICAL SLIDE SWITCH		UNIT : MM	DRWG NO.: XJ-DR-SS42H01-00		
3	BASE	PHENOLIC RESIN	1	NATURAL	MODEL: SS-42H01		SCALE: 2:1	DWN.	ZHOUYU	2003-4-13
2	FRAME	STEEL STRIP	1	Ni PLATED	ALL MATERIALS MUST BE COMPLIANT TO ROHS		APPD.	CHK'D	FANGYING	2003-4-13
1	KNOB	POM	1	BLACK				KANGXINAN	2003-4-13	
NO.	PART NAME	MATERIAL	Q'TY	FINISHING						